

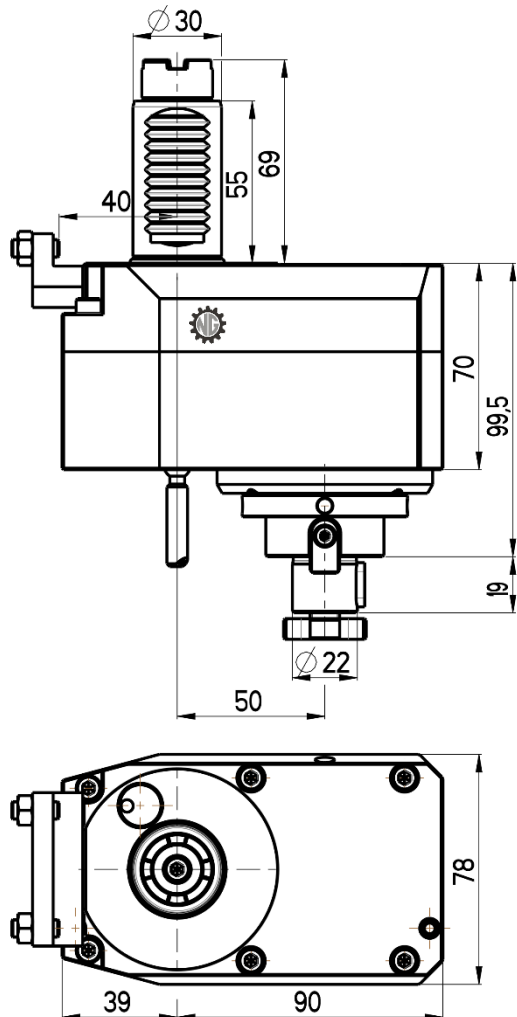

# OFFSET STRAIGHT LIVE TOOL HOLDER

VDI 30 / OKUMA

Product code:  
**NGT1-30/353-22/1.1-50JA(1:2)**



**Max. speed:** 12000 rpm

**Max. torque:** 14 Nm

**Shell mill:** Ø22

**Direction of rotation:** ↻ ↻

**Ratio:** 1:2

**Cooling:** external (internal cooling available)

### Accessories

**Nut :** Wrench DIN 6368 22



**Spindle:** Hook wrench DIN 1810B 52-55