

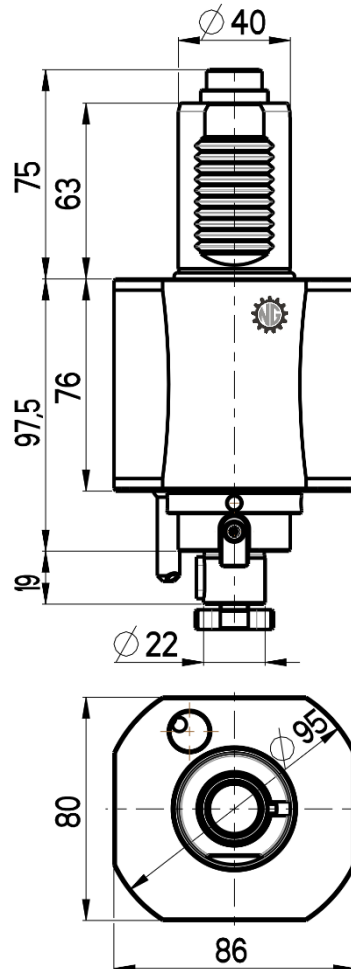

STRAIGHT LIVE TOOL HOLDER

VDI 40 / DIN 5480

Product code:
NGT1-40/133-22/1



Max. speed: 6000 rpm

Max. torque: 50 Nm

Shell mill: Ø22

Direction of rotation:

Ratio: 1:1

Cooling: external (internal cooling available)

Optional accessories

Nut : Wrench DIN 6368 22

Spindle: Hook wrench DIN 1810B 58-62

